

## Comparisons of Heat Transfer Enhancement of an Internal Blade Tip with Metal or Insulating Pins

Gongnan Xie<sup>1,2</sup> and Bengt Sundén<sup>2,\*</sup>

<sup>1</sup> *The Key Laboratory of Contemporary Design and Integrated Manufacturing Technology, Northwestern Polytechnical University, Xi'an 710072, Shaanxi, China*

<sup>2</sup> *Division of Heat Transfer, Lund University, SE-22100, Lund, Sweden*

Received 26 November 2009; Accepted (in revised version) 20 September 2010

Available online 28 February 2011

---

**Abstract.** Cooling methods are needed for turbine blade tips to ensure a long durability and safe operation. A common way to cool a tip is to use serpentine passages with 180-deg turn under the blade tip-cap taking advantage of the three-dimensional turning effect and impingement like flow. Improved internal convective cooling is therefore required to increase the blade tip lifetime. In the present study, augmented heat transfer of an internal blade tip with pin-fin arrays has been investigated numerically using a conjugate heat transfer method. The computational domain includes the fluid region and the solid pins as well as the tip regions. Turbulent convective heat transfer between the fluid and pins, and heat conduction within pins and tip are simultaneously computed. The main objective of the present study is to observe the effect of the pin material on heat transfer enhancement of the pin-finned tips. It is found that due to the combination of turning, impingement and pin-fin crossflow, the heat transfer coefficient of a pin-finned tip is a factor of 2.9 higher than that of a smooth tip at the cost of an increased pressure drop by less than 10%. The usage of metal pins can reduce the tip temperature effectively and thereby remove the heat load from the tip. Also, it is found that the tip heat transfer is enhanced even by using insulating pins having low thermal conductivity at low Reynolds numbers. The comparisons of overall performances are also included.

**AMS subject classifications:** 76D17, 80A20, 35Q80.

**Key words:** Heat transfer enhancement, tip-wall, pins, thermal conductivity, weight.

---

## 1 Introduction

Numerical simulations are effective means to investigate the details of fluid flow and heat transfer characteristics resulting from augmented surfaces. During recent years,

---

\*Corresponding author.

URL: [http://www.ht.energy.lth.se/personal/bengt\\_sunden](http://www.ht.energy.lth.se/personal/bengt_sunden)

Email: [xgn@nwpu.edu.cn](mailto:xgn@nwpu.edu.cn) (G. N. Xie), [Bengt.Sunden@energy.lth.se](mailto:Bengt.Sunden@energy.lth.se) (B. Sundén)

application of so-called *Computational Fluid Dynamics* (CFD) techniques to predict the flow field and heat transfer coefficient distribution in turbomachineries has attracted many researchers [1–6]. For examples, Hwang et al. [1] predicted turbulent heat transfer in a rotating two-pass channel using a modified two-equation  $k - \epsilon$  turbulence model. Chen et al. [2] calculated the 3D flow and heat transfer in a rotating two-pass square channel with smooth walls or  $45^\circ/60^\circ$  angled ribs by a second-moment closure model and a two-layer  $k - \epsilon$  isotropic eddy viscosity model. Iacovides and Raisee [3] computed fluid flow and heat transfer in 2D rib-roughened passages using modified low-Re differential second-moment (DSM) closure turbulence models. Nonino and Comini [4] computed 3D laminar forced convective heat transfer in ribbed square channels by using the velocity-pressure coupling algorithm SIMPLER. The work was based on the finite element method. Jia et al. [5] and Sundén et al. [6] numerically studied turbulent heat transfer and/or impingement cooling in rib-roughened ducts using the in-house code CALC-MP. From the above-mentioned references, it is indicated that heat transfer and cooling in gas turbine channels might be predicted effectively by CFD simulations with various computational approaches.

For turbine blades in particular operation, the hot leakage flow results in high thermal loads on the blade tip. It is therefore essential to cool the turbine blade tip and the region near the tip. A common way to cool the blade tip is to adopt internal cooling by designing serpentine (two-pass, three-pass or multi-pass) channels with a 180-deg turn/bend inside the blade (as shown in Fig. 1). Taking the advantage of impinging and turning effects, the tip can be cooled to some certain extent. Consequently, augmented internal convective cooling is required to increase the blade tip life. Fortunately, it is well documented that many augmented devices, i.e., fins, ribs, pins, dimples, can be used to improve the heat transfer significantly. Many previous investigations have proven that pin-fins can improve the cooling in low aspect ratio channels for gas turbines, typically at the trailing edges. The application of pin-fins has received considerably attention for enhancing heat transfer in cooling channels, e.g., turbine blades, heat sinks, compact heat exchangers. Metzger et al. [7] studied developing heat transfer in rectangular ducts having short pin-fin arrays. They found

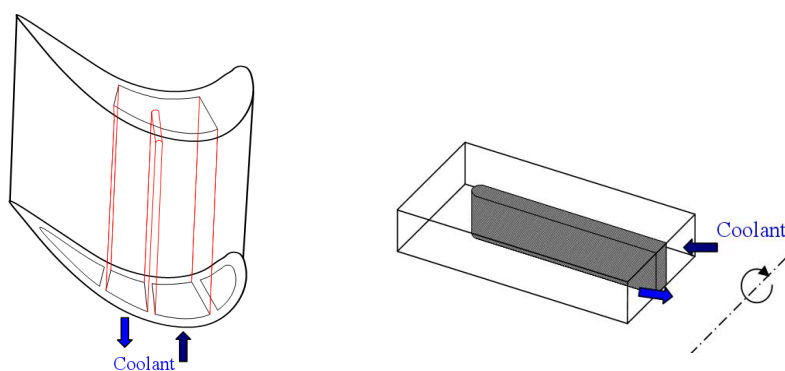

Figure 1: A typical serpentine passage inside a turbine blade.