

# Numerical Simulation of Orthotic Insole Deformation for Diabetic Foot

W. T. Lo<sup>a</sup>, K. L. Yick<sup>a,\*</sup>, S. P. Ng<sup>b</sup>, J. Yip<sup>a</sup>

<sup>a</sup>*Institute of Textiles and Clothing, The Hong Kong Polytechnic University, Hung Hom, Hong Kong*

<sup>b</sup>*Hong Kong Community College, The Hong Kong Polytechnic University, Hong Kong*

---

## Abstract

Custom-made orthotic insoles are routinely used in the treatment of the diabetic foot to reduce plantar pressure so as to minimise the risk of neuropathic ulceration. Due to the 3D geometry shape of the foot and insole, the measurement of the foot-orthosis interface pressure at different plantar regions in relation to insole material fabrication is vital for effective foot orthotic treatment. In the present study, a model of a custom-made three-layer contoured insole that simulates foot-insole interactions is developed by using finite element analysis. With the use of the insole material properties and plantar pressure distribution during balanced standing as the inputs, the magnitude of the deformity and the compressive stress distributed across the regions of the insole made of different combinations of materials are simulated. After validation, the simulated deformation shows good agreement with the result obtained by image processing technology. The simulation model not only provides a promising solution to the modification of materials for insoles by predicting and visualising insole deformation patterns, but also effectively optimises the design and development process of orthotic insoles without the need to fabricate and test the insoles in a series of wear trials.

*Keywords:* Orthotic Insoles; Insole Materials; Diabetic Foot; Numerical Simulation

---

## 1 Introduction

Peripheral neuropathy, peripheral arterial disease and susceptibility to infection are the major risk factors in foot ulcerations [1]. Due to the loss of the protective sensation that is associated with neuropathy, diabetics are unable to respond to pressure, cold and heat, minor cuts and injuries, or deep pain. Therefore, any wound or injury could quickly become infected and lead to serious health consequences. Ulceration can further lead to necrosis and eventually, the amputation of the foot or even the whole lower leg [2]. Ulceration might have long term effects, especially on localised prominent areas, thus resulting in skeletal deformities [3]. Even if the ulcer heals, there is still a high risk of recurrence which greatly deteriorates the quality of life.

---

\*Corresponding author.

*Email address:* tcyick@polyu.edu.hk (K. L. Yick).

Treatment with foot orthotics has been extensively used to prevent diabetic plantar ulceration in clinical practices. In considering the costly and complex processes of making orthopaedic shoes, orthotic insoles are regularly prescribed since much research has been done that prove their effectiveness for patients with diabetes. The insoles are specifically made by taking into consideration the foot morphology of the patient, thereby achieving total contact with the plantar surface. The function of orthotic insoles is to reduce the transmission of elevated plantar loads from prominent plantar bony prominences and redistribute plantar pressure over a wide surface area, thus reducing the risk of ulceration [4–8]. There are two basic types of customised orthotic insoles: accommodative and functional. The primary goal of using custom-made accommodative insoles is to accommodate deformities without correction, and shift pressure away from painful areas that are prone to occurrence and recurrence of ulcerations, whilst custom-made functional insoles provide mechanical control and correct the function of the foot [9, 10]. Multi-layered structures are normally adopted in the construction of orthotic insoles for the diabetic foot to provide the needed combination of accommodative and functional properties [11]. Each layer is designed to function differently in the insoles. The top layer is for accommodation purposes, which comes into direct contact with the foot and can conform to the foot so as to homogenise the plantar pressure and avoid high pressure points that may cause ulceration. The middle layer aims to provide cushioning to absorb the impact force during gait. Finally, the bottom layer is for control purposes and provide stability to the assembly [11, 12]. As indicated in the previous literature, the pressure distributions between the foot and the insole are greatly affected by the choice of foam materials in the constructing of the layers, and the 3D foot morphology and deformities, thus influencing the quality and effectiveness of the foot orthotic treatment.

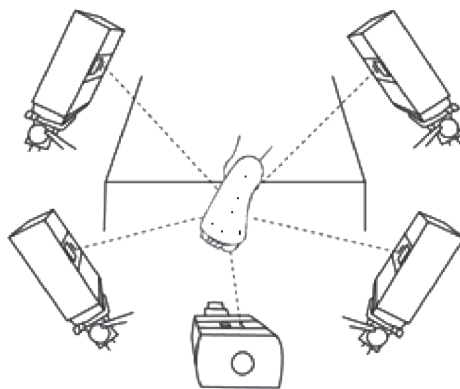

Fig. 1: Setup for foot scanning from five angles

Due to the particularities of the performance and mechanics of viscoelastic materials, a number of studies have investigated the physical and mechanical behavior of foam materials for orthotic footwear. Particular attention is also paid to the pressure redistribution performance of the materials. In considering the wide range of orthotic materials and lack of suitable technology for experimental measurements, computational methods, such as Finite Element (FE) analysis, have been adopted with great success to simulate in-shoe conditions to predict the load transfer mechanism in order to study the biomechanical behavior and performance of foot orthoses [13–15]. The results have provided plantar pressure distribution patterns and internal stresses and strains in the bony and soft tissue structures under various loadings and different structural and material configurations of foot orthoses, which have helped to investigate foot behaviour under different kinds of supports. Other researchers have developed foot models that incorporate foot anatomy