

## Lump and Interaction Solutions of the (2+1)-Dimensional bSK Equation

Hong-Cai Ma<sup>1,2,\*</sup>, Han-Fang Wu<sup>1</sup>, Wen-Xiu Ma<sup>3,4,5,6,\*</sup>  
and Ai-Ping Deng<sup>1,2</sup>

<sup>1</sup>Department of Applied Mathematics, Donghua University, Shanghai 201620, China.

<sup>2</sup>Institute for Nonlinear Sciences, Donghua University, Shanghai 201620, China.

<sup>3</sup>Department of Mathematics, Zhejiang Normal University, Jinhua 321004, Zhejiang, China.

<sup>4</sup>Department of Mathematics, King Abdulaziz University, Jeddah 21589, Saudi Arabia.

<sup>5</sup>Department of Mathematics and Statistics, University of South Florida, Tampa, FL 33620-5700, USA.

<sup>6</sup>School of Mathematical and Statistical Sciences, North-West University, Mafikeng Campus, Mmabatho 2735, South Africa.

Received 9 September 2020; Accepted (in revised version) 18 January 2021.

---

**Abstract.** In this paper, we study lump and interaction solutions of the (2+1)-dimensional bidirectional Sawada-Kotera equation. By using the Hirota bilinear method and considering a combined function with a positive quadratic function, we determine a few lump and interaction solutions of the bidirectional Sawada-Kotera equation. In order to ensure solvability of the corresponding solutions, five cases of necessary conditions for the parameters are explicitly presented. Dynamical properties of the resulting solutions are demonstrated, upon selecting appropriate values for the parameters.

**AMS subject classifications:** 35Q51, 35Q53, 35C99, 68W30, 74J35

**Key words:** Soliton, Hirota bilinear method, bidirectional Sawada-Kotera equation, lump solution, interaction solution.

---

### 1. Introduction

It is well known that the study on exact solutions of nonlinear equations plays a key role in nonlinear science. With the continuous advancement of research, solitons and important problems closely related to soliton theory have been found in many fields, such as physics, biology, medicine, oceanography, economics, and population problems. It is

---

\*Corresponding author. Email addresses: mawx@cas.usf.edu (W.-X. Ma), hongcaima@dhu.edu.cn (H.-C. Ma)

one of the most basic and important tasks in mathematics to find exact solutions of nonlinear equations. In recent years, more and more scholars have paid attention to exact solutions, particularly to nonlinear differential equations. Indeed, many powerful methods have been developed, which include the inverse scattering approach [1], the Bäcklund transformation [29, 31], Darboux transformation [28], C-K direct method [3, 11], Hirota bilinear approach [7], the auxiliary equation method [15], and the long wave limit method. In the recent study of nonlinear problems, the Hirota bilinear method has become a popular and efficient method to generate lump solutions. Very recently, in soliton theory, lump solutions have been attracting more and more attention [13, 14]. Lump solutions are a kind of regular and rationally function solutions, localised in all directions in the space [19], which appear in many physical phenomena. Amazingly, lump and interaction solutions have been presented and analysed for many nonlinear equations of mathematical physics [2, 6, 8, 9, 12, 16–18, 20–23, 26, 27, 30, 32, 34, 36–40], even for linear wave equations — cf. [24], and with higher-order dispersion relations [25].

In this paper, we will study lump and interaction solutions and their dynamics for a (2+1)-dimensional bidirectional Sawada-Kotera (bSK) equation. The (2+1)-dimensional bSK equation reads [10]

$$\begin{aligned} 9u_y - (5u_{xt} + 15u^3 + 15uu_{xx} + u_{xxx})_x - 15uu_t \\ + 5(\partial x)^{-1}u_{tt} - 15u_x(\partial x)^{-1}u_t = 0, \end{aligned} \quad (1.1)$$

which is subordinate to the Kadomtsev-Petviashvili equation. Here,  $(\partial x)^{-1} = (\partial/\partial x)^{-1}$  and  $u$  is a function of variables  $x, y$  and  $t$ . It was formulated as a bidirectional generalisation of the Sawada-Kotera (SK) equation [33]. Its bidirectionality and relationship with the SK equation was pointed out in [4]. In view of its connection with the SK equation, the bSK equation also belongs to the Kadomtsev-Petviashvili hierarchy of B-type (BKP hierarchy) [5], the first equation of which has been shown to possess lump solutions [35]. Therefore, it will be interesting to explore lump and interaction solutions to the (2+1)-dimensional bSK equation.

The structure of the rest of the paper is as follows. In Section 2, we present a Hirota bilinear form of the (2+1)-dimensional bSK equation by the Hirota bilinear method. Then, through analysis and symbolic computations with Maple, we compute exact solutions of the bSK equation. Some figures of the resulting lump and interaction solutions with appropriate choices of the involved parameters are made to exhibit energy distributions and dynamical properties. In Section 3, we give a brief conclusion to summarize our work.

## 2. Lump and Interaction Solutions for the (2+1)-Dimensional bSK Equation

### 2.1. Bilinear form for the bSK equation

Under the bilinear transformation

$$u = 2\partial_x^2 \ln f, \quad (2.1)$$

where  $f(x, y, t)$  is unknown real function, the Eq. (1.1) can be transformed into the bilinear forms as follows:

$$\begin{aligned} B_{bSK}(f) &:= (9D_x D_y - 5D_x^3 D_t - D_x^6 + 5D_t^2) f \cdot f \\ &= 2 \left[ 9(f_{xy} f - f_x f_y) - 5(f_{xxx} f - f_{xxx} f_t + 3f_{xx} f_{xt} - 3f_x f_{xxt}) \right. \\ &\quad \left. - (f_{xxxx} f - 6f_{xxxx} f_x + 15f_{xxxx} f_{xx} - 10f_{xxx}^2) + 5(f_{tt} f - f_t^2) \right], \end{aligned} \quad (2.2)$$

where  $D_t, D_x, D_y$  are the bilinear derivative operators [7] defined by

$$D_x^m D_y^n D_t^q f \cdot g = (\partial_x - \partial_{x'})^m (\partial_y - \partial_{y'})^n (\partial_t - \partial_{t'})^q \times f(x, y, t) g(x', y', t')|_{x'=x, y'=y, t'=t},$$

where  $m, n$  and  $q$  are the positive integers,  $f$  is the function of  $x, y$  and  $t$ , and  $g$  is the function of the formal variables  $x', y'$  and  $t'$ .

## 2.2. Lump and interaction solutions for bSK equation

In this section, we make  $f(x, y, t)$  as a combination of positive quadratic function with trigonometric function and exponential functions (The positive polynomial part in  $f$  contributes to the lump, the trigono-metric function part, to the breather, and the exponential function part, to the soliton), that is

$$\begin{aligned} f(x, y, t) &= g^2 + h^2 + a_9 \cos(a_{10}x + a_{11}y + a_{12}t + a_{13}) \\ &\quad + \exp(-(a_{14}x + a_{15}y + a_{16}t + a_{17})) \\ &\quad + a_{18} \exp(a_{14}x + a_{15}y + a_{16}t + a_{17}), \end{aligned} \quad (2.3)$$

where two linear wave variables are defined by

$$\begin{aligned} g &= a_1 x + a_2 y + a_3 t + a_4, \\ h &= a_5 x + a_6 y + a_7 t + a_8, \end{aligned}$$

where  $a_i, i = 1, \dots, 18$  are real numbers to be confirmed later. Substituting (2.3) into (2.2), then we obtain a group of equations for the parameters. Next, equating all the coefficients of independent variables to zeros, we obtain a set of parameters. After analysis and calculations, we get a series of relationships between parameters. The solutions are as follows.

**Case 1.** In order to get lump solution of bSK equation, we set  $a_i = 0, i \geq 10$ . After calculation, we can get the lump solutions as follows:

$$\begin{aligned} u(x, y, t) &= \frac{4a_5^2}{(-Gy + a_3t + a_4)^2 + (a_5x - Hy + Dt + a_8)^2 + a_9} \\ &\quad - \frac{8a_5^2(a_5x - Hy + Dt + a_8)^2}{((-Gy + a_3t + a_4)^2 + (a_5x - Hy + Dt + a_8)^2 + a_9)^2}, \end{aligned} \quad (2.4)$$

and

$$u(x, y, t) = \frac{4(a_1^2 + a_5^2)}{(a_1x - Ey + a_3t + a_4)^2 + (a_5x - Fy + a_7t + a_8)^2 + C} - \frac{2(2(a_1x - Ey + a_3t + a_4)a_1 + 2(a_5x - Fy + a_7t + a_8)a_5)^2}{((a_1x - Ey + a_3t + a_4)^2 + (a_5x - Fy + a_7t + a_8)^2 + C)^2}, \quad (2.5)$$

where

$$G = \frac{10a_3^3a_9}{27a_5^4}, \quad H = \frac{5a_3^2(-9a_5^6 + a_3^2a_9^2)}{81a_5^7}, \quad D = \frac{a_3^2a_9}{3a_5^3},$$

$$C = \frac{1}{(a_1a_7 - a_3a_5)^2} \left( 3a_1^5a_3 + 3a_1^4a_5a_7 + 6a_1^3a_3a_5^2 + 4a_1^2a_3a_4a_7a_8 \right. \\ \left. + 6a_1^2a_5^3a_7 - 2a_1a_3^2a_4a_5a_8 \right. \\ \left. + 3a_1a_3a_5^4 + 2a_1a_4a_5a_7^2a_8 + 3a_5^5a_7 \right),$$

$$E = \frac{5(a_1a_3^2 - a_1a_7^2 + 2a_3a_5a_7)}{9a_1^2 + 9a_5^2}, \quad F = \frac{5(2a_1a_3a_7 - a_3^2a_5 + a_5a_7^2)}{9a_1^2 + 9a_5^2},$$

and  $a_1a_7 - a_3a_5 \neq 0$ . Fig. 1 shows 3D plots and contour plot of these two solutions at  $t = 0$ , respectively.

**Case 2.** In this case

$$\begin{aligned} a_2 = 0, \quad a_3 = 0, \quad a_6 = 0, \quad a_7 = 0, \quad a_{10} = 0, \\ a_{11} = 0, \quad a_{12} = 0, \quad a_{15} = -a_{14}^5, \quad a_{16} = -a_{14}^3, \quad a_{18} = 0, \\ a_i = a_i, \quad i = 1, 4, 5, 8, 9, 13, 14, 17. \end{aligned} \quad (2.6)$$

Substituting (2.6) into (2.3), we have

$$\begin{aligned} f(x, y, t) = (a_1x + a_4)^2 + (a_5x + a_8)^2 + a_9 \cos(a_{13}) \\ + \exp(a_{14}^5y + a_{14}^3t - a_{14}x - a_{17}). \end{aligned} \quad (2.7)$$

Substituting (2.7) into (2.1), we can get the form of  $u$

$$\begin{aligned} u(x, y, t) = \frac{2(2a_1^2 + 2a_5^2 + a_{14}^2 \exp(a_{14}^5y + a_{14}^3t - a_{14}x - a_{17}))}{(a_1x + a_4)^2 + (a_5x + a_8)^2 + a_9 \cos(a_{13}) + \exp(a_{14}^5y + a_{14}^3t - a_{14}x - a_{17})} \\ - \frac{2(2(a_1x + a_4)a_1 + 2(a_5x + a_8)a_5 - a_{14} \exp(a_{14}^5y + a_{14}^3t - a_{14}x - a_{17}))^2}{((a_1x + a_4)^2 + (a_5x + a_8)^2 + a_9 \cos(a_{13}) + \exp(a_{14}^5y + a_{14}^3t - a_{14}x - a_{17}))^2}. \end{aligned}$$

In Fig. 2, we give two different plots to show the change of  $u$ . That is a soliton with a lump wave.

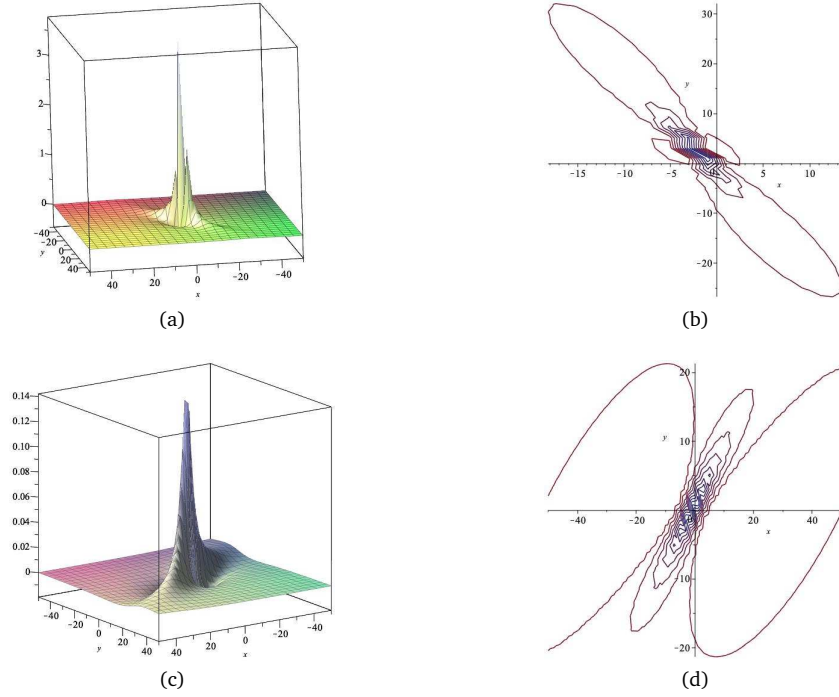

Figure 1: Spatiotemporal structure of solution (2.4) with the parameter selections  $a_1 = 1, a_4 = 1, a_5 = 1, a_8 = 1, a_9 = 1$ ; (a)  $t = 0$ ; (b) contour plots (top)  $t = 0$ . Spatiotemporal structure of solution (2.5) with the parameter selections  $a_1 = 1, a_4 = 1, a_5 = 1, a_8 = 1, a_9 = 1, a_{13} = 1, a_{14} = 1, a_{17} = 2$ ; (c)  $t = 0$ ; (d) contour plots (top)  $t = 0$ .

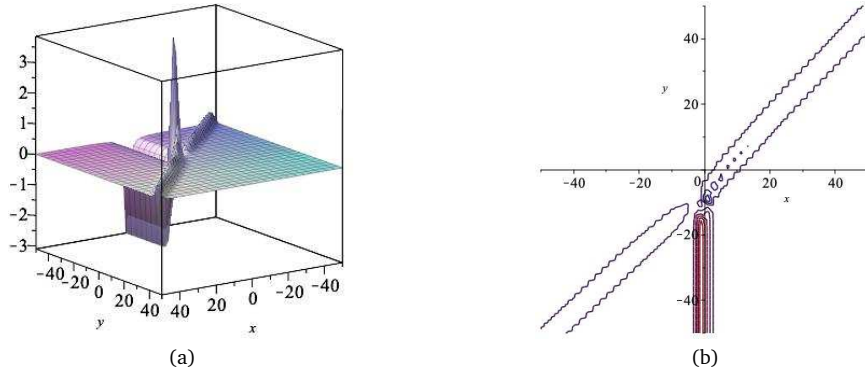

Figure 2: Spatiotemporal structure of solution  $u$  with the parameter selections  $a_1 = 2, a_4 = 1, a_5 = 2, a_8 = 1, a_9 = 2, a_{13} = 1, a_{14} = 1, a_{17} = 2$ ; (a)  $t = 15$ ; (b) contour plots (top)  $t = 15$ .

Furthermore, in next case, we show a special form in Case 2.

$$\begin{aligned}
 a_2 &= 0, & a_3 &= 0, & a_6 &= 0, & a_7 &= 0, \\
 a_9 &= 0, & a_{15} &= -a_{14}^5, & a_{16} &= -a_{14}^3, & a_{18} &= 0, \\
 a_i &= a_i, & i &= 1, 4, 5, 8, 14, 17.
 \end{aligned}
 \tag{2.8}$$

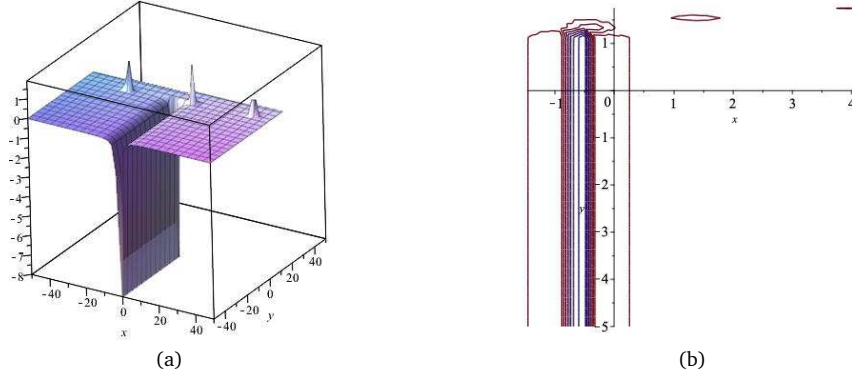

Figure 3: Spatiotemporal structure of solution  $u$  with the parameter selections  $a_1 = 1$ ,  $a_4 = 1$ ,  $a_5 = 2$ ,  $a_8 = 1$ ,  $a_{14} = 2$ ,  $a_{17} = 3$ , (a)  $t = -5$ ; (b) contour plots (top)  $t = -5$ .

Substituting (2.8) into (2.3), we get the concrete form of the function  $f$

$$f(x, y, t) = (a_1x + a_4)^2 + (a_5x + a_8)^2 + \exp(a_{14}^5y + a_{14}^3t - a_{14}x - a_{17}). \quad (2.9)$$

Substituting (2.9) into (2.1), we obtain the exact solution of the Eq. (1.1). Then we have

$$u(x, y, t) = \frac{2(2a_1^2 + 2a_5^2 + a_{14}^2 \exp(a_{14}^5y + a_{14}^3t - a_{14}x - a_{17}))}{(a_1x + a_4)^2 + (a_5x + a_8)^2 + \exp(a_{14}^5y + a_{14}^3t - a_{14}x - a_{17})} - \frac{2(2(a_1x + a_4)a_1 + 2(a_5x + a_8)a_5 - a_{14} \exp(a_{14}^5y + a_{14}^3t - a_{14}x - a_{17}))^2}{((a_1x + a_4)^2 + (a_5x + a_8)^2 + \exp(a_{14}^5y + a_{14}^3t - a_{14}x - a_{17}))^2}.$$

When the values of these parameters are changed, the structure of the lump solutions will also change accordingly. Here, the spatial variation of  $u$  is shown in Fig. 3. That are breathers with a rogue wave.

**Case 3.** In this case

$$\begin{aligned} a_1 &= \frac{2}{3} \frac{a_7}{a_{14}^2}, & a_2 &= \frac{5}{6} a_{14}^2 a_7, & a_3 &= -\frac{3}{2} a_{14}^2 a_5, & a_6 &= \frac{5}{4} a_{14}^4 a_5, \\ a_9 &= 0, & a_{15} &= \frac{1}{4} a_{14}^5, & a_{16} &= \frac{1}{2} a_{14}^3, & a_{18} &= 0, \\ a_{14} &\neq 0, & a_i &= a_i, & i &= 4, 5, 7, 8, 14, 17. \end{aligned} \quad (2.10)$$

Substituting (2.10) into (2.3), we get the quadratic function  $f$

$$\begin{aligned} f(x, y, t) &= \left( \frac{2}{3} \frac{a_7x}{a_{14}^2} + \frac{5}{6} a_{14}^2 a_7 y - \frac{3}{2} a_{14}^2 a_5 t + a_4 \right)^2 + \left( a_5x + \frac{5}{4} a_{14}^4 a_5 y + a_7 t + a_8 \right)^2 \\ &+ \exp\left(-a_{14}x - \frac{1}{4} a_{14}^5 y - \frac{1}{2} a_{14}^3 t - a_{17}\right). \end{aligned} \quad (2.11)$$

Substituting (2.11) into (2.1), we obtain the value of  $u$

$$u(x, y, t) = \frac{2 \left( \frac{8}{9} \frac{a_7^2}{a_{14}^4} + 2a_5^2 + a_{14}^2 \exp(-a_{14}x - \frac{1}{4}a_{14}^5 y - \frac{1}{2}a_{14}^3 t - a_{17}) \right)}{k_1^2 + k_2^2 + \exp(-a_{14}x - \frac{1}{4}a_{14}^5 y - \frac{1}{2}a_{14}^3 t - a_{17})} - \frac{2 \left( \frac{4}{3} \frac{k_1 a_7}{a_{14}^2} + 2k_2 a_5 - a_{14} \exp(-a_{14}x - \frac{1}{4}a_{14}^5 y - \frac{1}{2}a_{14}^3 t - a_{17}) \right)^2}{(k_1^2 + k_2^2 + \exp(-a_{14}x - \frac{1}{4}a_{14}^5 y - \frac{1}{2}a_{14}^3 t - a_{17}))^2},$$

where two linear variables are defined by

$$k_1 = \frac{2}{3} \frac{a_7 x}{a_{14}^2} + \frac{5}{6} a_{14}^2 a_7 y - \frac{3}{2} a_{14}^2 a_5 t + a_4,$$

$$k_2 = a_5 x + \frac{5}{4} a_{14}^4 a_5 y + a_7 t + a_8.$$

Here, we put two plots to present the change of lump solution — cf. Fig. 4. That is a soliton with a lump wave.

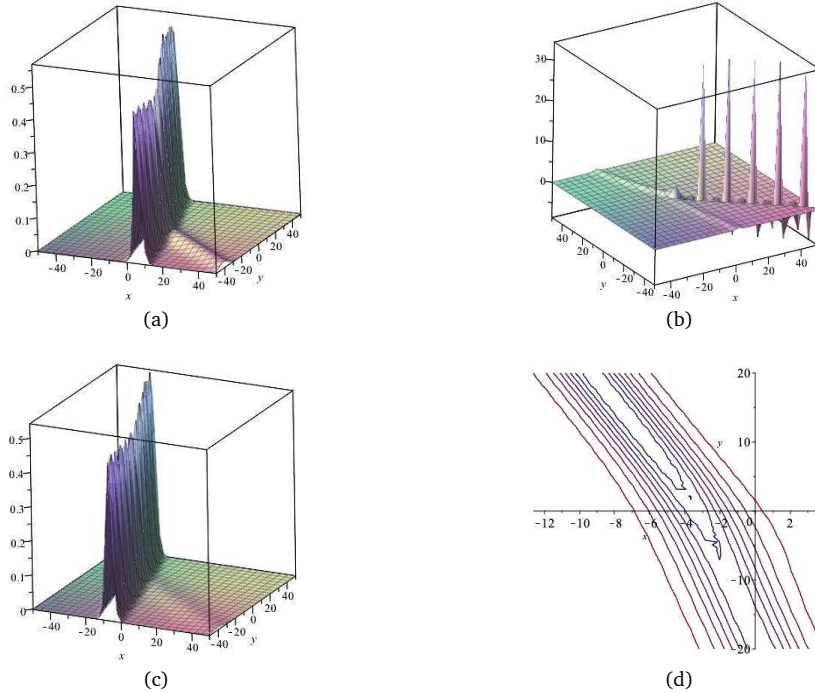

Figure 4: Spatiotemporal structure of solution  $u$  with the parameter selections:  $a_4 = 2$ ,  $a_5 = 1$ ,  $a_7 = 2$ ,  $a_8 = 2$ ,  $a_{14} = 1$ ,  $a_{17} = 2$ , (a)  $t = -10$ ; (b)  $t = 0$ ; (c)  $t = 15$ , (d) contour plots (top)  $t = -10$ .

**Case 4.** In this case

$$\begin{aligned} a_1 &= -\frac{2}{3} \frac{a_7}{a_{14}^2}, & a_2 &= -\frac{5}{6} a_{14}^2 a_7, & a_3 &= \frac{3}{2} a_{14}^2 a_5, & a_6 &= \frac{5}{4} a_{14}^4 a_5, \\ a_9 &= 0, & a_{15} &= \frac{1}{4} a_{14}^5, & a_{16} &= \frac{1}{2} a_{14}^3, & a_{18} &= 0, \\ a_{14} &\neq 0, & a_i &= a_i, & i &= 4, 5, 7, 8, 14, 17. \end{aligned} \quad (2.12)$$

Substituting (2.12) into (2.3), we get the form of the function  $f$

$$\begin{aligned} f(x, y, t) &= \left( -\frac{2}{3} \frac{a_7 x}{a_{14}^2} - \frac{5}{6} a_{14}^2 a_7 y + \frac{3}{2} a_{14}^2 a_5 t + a_4 \right)^2 + \left( a_5 x + \frac{5}{4} a_{14}^4 a_5 y + a_7 t + a_8 \right)^2 \\ &+ \exp \left( -a_{14} x - \frac{1}{4} a_{14}^5 y - \frac{1}{2} a_{14}^3 t - a_{17} \right). \end{aligned} \quad (2.13)$$

Substituting (2.13) into (2.1), we have

$$\begin{aligned} u(x, y, t) &= \frac{2 \left( \frac{8}{9} \frac{a_7^2}{a_{14}^4} + 2a_5^2 + a_{14}^2 \exp \left( -a_{14} x - \frac{1}{4} a_{14}^5 y - \frac{1}{2} a_{14}^3 t - a_{17} \right) \right)}{l_1^2 + l_2^2 + \exp \left( -a_{14} x - \frac{1}{4} a_{14}^5 y - \frac{1}{2} a_{14}^3 t - a_{17} \right)} \\ &- \frac{2 \left( -\frac{4}{3} \frac{l_1 a_7}{a_{14}^2} + 2l_2 a_5 - a_{14} \exp \left( -a_{14} x - \frac{1}{4} a_{14}^5 y - \frac{1}{2} a_{14}^3 t - a_{17} \right) \right)^2}{(l_1^2 + l_2^2 + \exp \left( -a_{14} x - \frac{1}{4} a_{14}^5 y - \frac{1}{2} a_{14}^3 t - a_{17} \right))^2}, \end{aligned}$$

where two linear variables are defined by

$$\begin{aligned} l_1 &= -\frac{2}{3} \frac{a_7 x}{a_{14}^2} - \frac{5}{6} a_{14}^2 a_7 y + \frac{3}{2} a_{14}^2 a_5 t + a_4, \\ l_2 &= a_5 x + \frac{5}{4} a_{14}^4 a_5 y + a_7 t + a_8. \end{aligned}$$

In Fig. 5, we can get the change of  $u$ . That is a soliton with a lump wave.

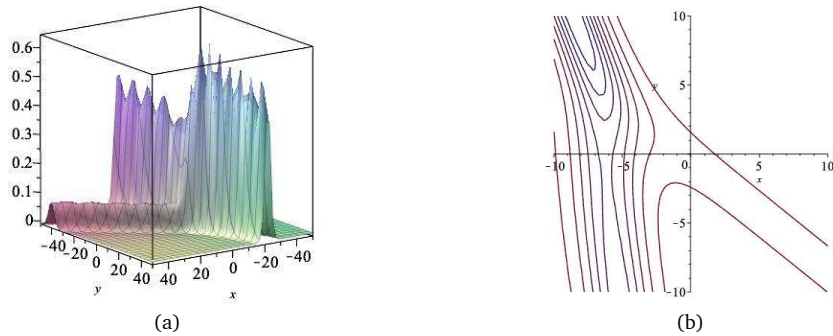

Figure 5: Spatiotemporal structure of solution  $u$  with the parameter selections  $a_4 = 1$ ,  $a_5 = 3$ ,  $a_7 = 2$ ,  $a_8 = 2$ ,  $a_{14} = 1$ ,  $a_{17} = 2$ , (a)  $t = -5$ ; (b) contour plots (top)  $t = -5$ .



**Case 5.** In this case

$$\begin{aligned} a_2 = 0, \quad a_3 = 0, \quad a_6 = 0, \quad a_7 = 0, \\ a_9 = 0, \quad a_{15} = -a_{14}^5, \quad a_{16} = -a_{14}^3, \\ a_{14} \neq 0, \quad a_i = a_i, \quad i = 1, 4, 5, 8, 14, 17, 18. \end{aligned} \quad (2.14)$$

Substituting (2.14) into (2.3), we get the form of the function  $f$

$$\begin{aligned} f(x, y, t) = (a_1x + a_4)^2 + (a_5x + a_8)^2 + \exp(a_{14}^5y + a_{14}^3t - a_{14}x - a_{17}) \\ + a_{18} \exp(-a_{14}^5y - a_{14}^3t + a_{14}x + a_{17}). \end{aligned} \quad (2.15)$$

Substituting (2.15) into (2.1), we have

$$\begin{aligned} u(x, y, t) = \frac{2(2a_1^2 + 2a_5^2 + a_{14}^2 \exp(A)) + a_{18}a_{14}^2 \exp(B)}{(a_1x + a_4)^2 + (a_5x + a_8)^2 + \exp(A) + a_{18} \exp(B)} \\ - \frac{2(2(a_1x + a_4)a_1 + 2(a_5x + a_8)a_5 - a_{14} \exp(A) + a_{18}a_{14} \exp(B))^2}{((a_1x + a_4)^2 + (a_5x + a_8)^2 + \exp(A) + a_{18} \exp(B))^2}, \end{aligned}$$

where two linear variables are defined by

$$\begin{aligned} A &= a_{14}^5y + a_{14}^3t - a_{14}x - a_{17}, \\ B &= -a_{14}^5y - a_{14}^3t + a_{14}x + a_{17}. \end{aligned}$$

In Fig. 6, three-dimensional plots and contour plots of the lump solutions  $u$  are made via Maple plot tools, to shed light on the characteristic of the lump solutions. That is a soliton with a lump wave.

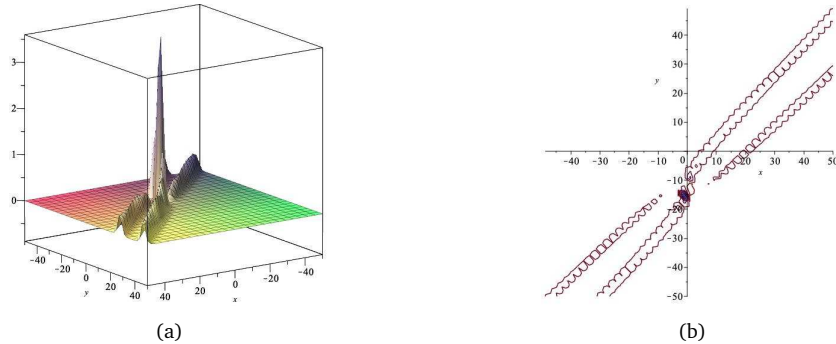

Figure 6: Spatiotemporal structure of solution  $u$  with the parameter selections  $a_1 = 2, a_4 = 1, a_5 = 2, a_9 = 2, a_8 = 1, a_{13} = 1, a_{14} = 1, a_{17} = -2, a_{18} = 2$ , (a)  $t = 15$ ; (b) contour plots (top)  $t = 15$ .

### 3. Conclusions

In this paper, we have studied the (2+1)-dimensional bidirectional Sawada-Kotera equation. Based on the Hirota bilinear method and symbolic computations, we have transformed the (2+1)-dimensional bSK equation into a Hirota bilinear form. Through choosing a combed function with a quadratic function and symbolic computation with Maple, five classes of lump and interaction solutions to the (2+1)-dimensional bSK equation have been obtained. We have also made different plots with particular choices of the involved parameters to show energy distributions and dynamical properties of the resulting lump and interaction solutions. It is hoped that our results could be helpful in generating exact wave solutions to nonlinear dispersive wave equations in higher dimensions and recognizing propagation and interaction characteristics of nonlinear waves.

### Acknowledgments

The work is supported by the National Natural Science Foundation of China (Project Nos. 11371086, 11671258, 11975145), by the Fund of Science and Technology Commission of Shanghai Municipality (Project No. 13ZR1400100), by the Fund of Donghua University, Institute for Non-Linear Sciences and by the Fundamental Research Funds for the Central Universities with contract number 2232021G-13.

### References

- [1] M.J. Ablowitz and P.A. Clarkson, *Solitons, Nonlinear Evolution Equations and Inverse Scattering*, Cambridge University Press (1991).
- [2] J.C. Chen and Y.Z. Li, *M-lump and lump-kink solutions of (2+1)-dimensional Caudrey-Dodd-Gibbon-Kotera-Sawada equation*, *Pramana* **94**, 105 (2020).
- [3] P.A. Clarkson and M.D. Kruskal, *New similarity reductions of the Boussinesq equation*, *J. Math. Phys.* **30**, 2201–2213 (1989).
- [4] J.M. Dye and A. Parker, *On bidirectional fifth-order nonlinear evolution equations, Lax pairs, and directionally dependent solitary waves*, *J. Math. Phys.* **42**, 2567–2589 (2001).
- [5] J.M. Dye and A. Parker, *A bidirectional Kaup-Kupershmidt equation and directionally dependent solitons*, *J. Math. Phys.* **43**, 4921–4949 (2002).
- [6] D. Guo, S.F. Tian, X.B. Wang and T.T. Zhang, *Dynamics of lump solutions, rogue wave solutions and traveling wave solutions for a (3 + 1)-dimensional VC-BKP equation*, *East Asian J. Appl. Math.* **9**, 780–796 (2019).
- [7] R. Hirota, *The Direct Method in Soliton Theory*, Cambridge University Press (2004).
- [8] L.L. Huang and Y. Chen, *Localized excitations and interactional solutions for the reduced Maxwell-Bloch equations*, *Commun. Nonlinear Sci. Numer. Simulat.* **67**, 237–252 (2019).
- [9] L.L. Huang, Y.F. Yue and Y. Chen, *Localized waves and interaction solutions to a (3+1)-dimensional generalized KP equation*, *Comput. Math. Appl.* **76**, 831–844 (2018).
- [10] Z.G. Liu, *Abundant mixed lump-kink solutions to a (2+1)-dimensional bSK equation*, *Mod. Phys. Lett. B.* **32**, 1850313 (2018).
- [11] S.Y. Lou and H.C. Ma, *Non-Lie symmetry groups of (2+1)-dimensional nonlinear systems obtained from a simple direct method*, *J. Phys. A. Math. Gen.* **38**, L129–L137 (2005).

- [12] H.C. Ma, Y.X. Bai and A.P. Deng, *Multiple lump solutions of the (2+1)-dimensional Konopelchenko-Dubrovsky equation*, Math. Method Appl. Sci. **43**, 7135–7142 (2020).
- [13] H.C. Ma, Y.X. Bai and A.P. Deng, *Multiple lump solutions of the (4+1)-dimensional Fokas equation*, Adv. Math. Phys. **2020**, 3407676 (2020).
- [14] H.C. Ma and A.P. Deng, *Lump solution of (2+1)-dimensional Boussinesq equation*, Commun. Theor. Phys. **65**, 546–552 (2016).
- [15] H.C. Ma, Z.Y. Qin and A.P. Deng, *Lie symmetry and exact solution of (2+1)-dimensional generalized KP equation with variable coefficients*, Therm. Sci. **17**, 1490–1493 (2013).
- [16] H.C. Ma, H.F. Wu and A.P. Deng, *Novel interaction phenomena of localised waves in the (2 + 1)-dimensional HSI equation*, East Asian J. Appl. Math. **10**, 485–498 (2020).
- [17] H.C. Ma, C.Y. Zhang and A.P. Deng, *Breather wave solutions and interaction solutions for two mixed Calogero-Bogoyavlenskii-Schiff and Bogoyavlensky-Konopelchenko equations*, Adv. Math. Phys. **2020**, 1458280 (2020).
- [18] H.C. Ma, C.Y. Zhang and A.P. Deng, *New periodic wave, cross-kink wave, breather, and the interaction phenomenon for the (2 + 1)-dimensional Sharmo-Tasso-Olver equation*, Complexity. **2020**, 4270906 (2020).
- [19] W.X. Ma, *Lump solutions to the Kadomtsev-Petviashvili equation*, Phys. Lett. A. **379**, 1975–1978 (2015).
- [20] W.X. Ma, *Riemann-Hilbert problems and N-soliton solutions for a coupled mKdV system*, J. Geo. Phys. **132**, 45–54 (2018).
- [21] W.X. Ma, *A search for lump solutions to a combined fourth-order nonlinear PDE in (2+1)-dimensions*, J. Appl. Anal. Comput. **9**, 1319–1332 (2019).
- [22] W.X. Ma, *Interaction solutions to Hirota-Satsuma-Ito equation in (2+1)-dimensions*, Front. Math. China. **14**, 619–629 (2019).
- [23] W.X. Ma, *Lump and interaction solutions of linear PDEs in (3+1)-dimensions*, East Asian J. Appl. Math. **9**, 185–194 (2019).
- [24] W.X. Ma, *Lump and interaction solutions to linear PDEs in 2+1 dimensions via symbolic computation*, Mod. Phys. Lett. B. **33**, 1950457 (2019).
- [25] W.X. Ma and L.Q. Zhang, *Lump solutions with higher-order rational dispersion relations*, Pramana. **94**, 43 (2020).
- [26] W.X. Ma and Y. Zhou, *Lump solutions to nonlinear partial differential equations via Hirota bilinear forms*, J. Diff. Equ. **264**, 2633–2659 (2018).
- [27] J. Manafian and M. Lakestani, *Lump-type solutions and interaction phenomenon to the bidirectional Sawada-Kotera equation*, Pramana. **92**, 13–41 (2019).
- [28] V.B. Matveev and M.A. Salle, *Darboux Transformations and Solitons*, Springer (1991).
- [29] R.M. Miura (Ed), *Bäcklund Transformations, the Inverse Scattering Method, Solitons, and Their Applications: NSF Research Workshop on Contact Transformations*, Springer (1976).
- [30] R. Radha, C. Senthil Kumar and R. Saranya, *Inelastic dromions, rogue waves and lumps of (2+1)-dimensional long dispersive wave equation*, Wave Motion. **85**, 114–124 (2019).
- [31] C. Rogers and W.F. Shadwick, *Bäcklund Transformations and Their Applications*, Academic Press (1982).
- [32] H.Y. Ruan and Z.F. Li, *Interaction between line soliton and algebraic soliton for asymmetric Nizhnik-Novikov-Veselov equation*, Commun. Theo. Phys. **49**, 1547–1552 (2008).
- [33] K. Sawada and T. Kotera, *A Method for finding N-soliton solutions of the K.d.V. equation and K.d.V.-like equation*, Prog. Theor. Phys. **51**, 1355–1367 (1974).
- [34] P.X. Wu and Y.F. Zhang, *Lump, lumpoff and predictable rogue wave solutions to the (2+1)-dimensional asymmetrical Nizhnik-Novikov-Veselov equation*, Phys. Lett. A. **383**, 1755–1763 (2019).

- [35] J.Y. Yang and W.X. Ma, *Lump solutions to the BKP equation by symbolic computation*, Int. J. Mod. Phys. B. **30**, 1640028 (2016).
- [36] X.L. Yong, Y.N. Chen, Y.H. Huang and W.X. Ma, *Lump solutions of the modified Kadomtsev-Petviashvili-I equation*, East Asian J. Appl. Math. **10**, 420–426 (2020).
- [37] Y.F. Yue, L.L. Huang and Y. Chen, *Localized waves and interaction solutions to an extended (3+1)-dimensional Jimbo-Miwa equation*, Appl. Math. Lett. **89**, 70–77 (2019).
- [38] L.D. Zhang, S.F. Tian, W.Q. Peng, T.T. Zhang and X.J. Yan, *The dynamics of lump, lumpoff and rogue wave solutions of (2+1)-dimensional Hirota-Satsuma-Ito equations*, East Asian J. Appl. Math. **10**, 243–255 (2020).
- [39] X.E. Zhang, Y. Chen and Y. Zhang, *Breather, lump and X soliton solutions to nonlocal KP equation*, Comput. Math. App. **74**, 2341–2347 (2017).
- [40] Z.L. Zhao, Y. Chen and B. Han, *Lump soliton, mixed lump stripe and periodic lump solutions of a (2+1)-dimensional asymmetrical Nizhnik-Novikov-Veselov equation*, Mod. Phys. Lett. B **31**, 1750157 (2017).